

SC18CLX.2 LBP Compressor R404A/R507 220-240V 50Hz

General

Code number	104L2197
Approvals	EN 60335-2-34
Compressors on pallet	80

Application

Application	LBP		
Frequency	Hz	50	60
Evaporating temperature	°C	-45 to -10	-
Voltage range	V	198 - 254	-
Max. condensing temperature continuous (short)	°C	55 (60)	-
Max. winding temperature continuous (short)	°C	125 (135)	-

Cooling requirements

Frequency	Hz	50			60		
Application		LBP	MBP	HBP	LBP	MBP	HBP
32°C		F ₂	-	-	-	-	-
38°C		F ₂	-	-	-	-	-
43°C		F ₂	-	-	-	-	-

Remarks on application: 207-254V above -15°C evaporating temperature

Motor

Motor type	CSIR		
LRA (rated after 4 sec. UL984), HST LST	A	23.5	-
Cut in Current, HST LST	A	23.5	-
Resistance, main start winding (25°C)	Ω	3.3	14.0

Design

Displacement	cm ³	17.68
Oil quantity (type)	cm ³	600 (polyolester)
Maximum refrigerant charge	g	1300
Free gas volume in compressor	cm ³	1460
Weight without electrical equipment	kg	13.8

Dimensions

Height	mm	A	219
		B	213
		B1	193
		B2	110
Suction connector	location/I.D. mm angle	C	10.2 37°
	material comment		Copper Rubber plug
Process connector	location/I.D. mm angle	D	6.2 37°
	material comment		Copper Rubber plug
Discharge connector	location/I.D. mm angle	E	6.2 37°
	material comment		Copper Rubber plug
Oil cooler connector	location/I.D. mm angle	F	-
	material comment		-
Connector tolerance	I.D. mm		±0.09
Remarks:			

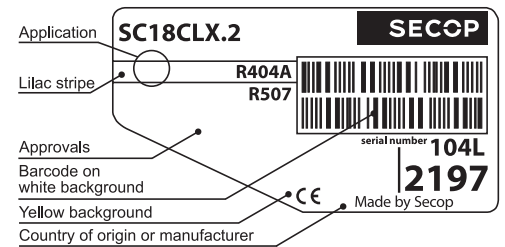

- S = Static cooling normally sufficient
- O = Oil cooling
- F₁ = Fan cooling 1.5 m/s (compressor compartment temperature equal to ambient temperature)
- F₂ = Fan cooling 3.0 m/s necessary
- SG = Suction gas cooling normally sufficient
- = not applicable in this area

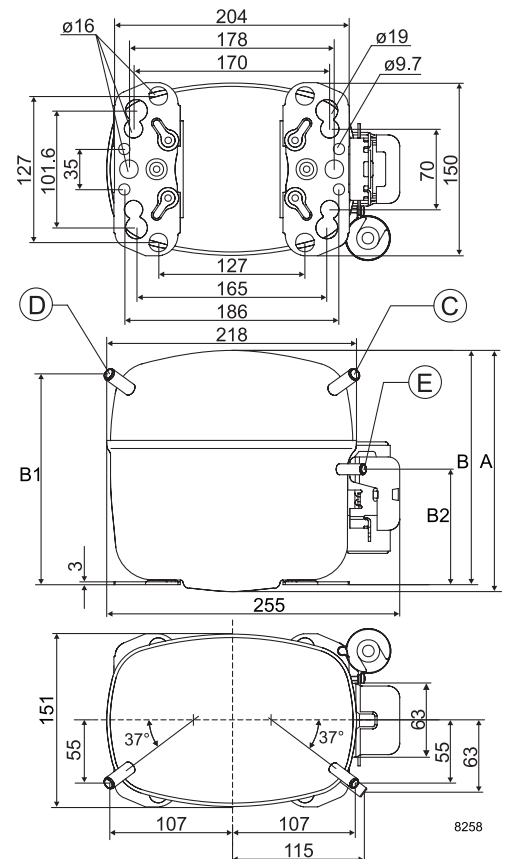

EN 12900 Household (CECOMAF)* 220V, 50Hz, fan cooling F₂

Evap. temp. in °C	-45	-40	-35	-30	-25	-23.3	-20	-15	-10	-6.7	-5	0	5	7.2	10	15	20
Capacity in W	194	306	439	595	780	849	995	1245	1532								
Power cons. in W	354	436	517	598	680	708	765	854	949								
Current cons. in A	3.13	3.40	3.68	3.98	4.28	4.39	4.60	4.92	5.26								
COP in W/W	0.55	0.70	0.85	1.00	1.15	1.20	1.30	1.46	1.61								

ASHRAE LBP* 220V, 50Hz, fan cooling F₂

Evap. temp. in °C	-45	-40	-35	-30	-25	-23.3	-20	-15	-10	-6.7	-5	0	5	7.2	10	15	20
Capacity in W	225	355	508	691	905	986	1156	1447	1783								
Power cons. in W	354	436	517	598	680	708	765	854	949								
Current cons. in A	3.13	3.40	3.68	3.98	4.28	4.39	4.60	4.92	5.26								
COP in W/W	0.64	0.81	0.98	1.16	1.33	1.39	1.51	1.69	1.88								

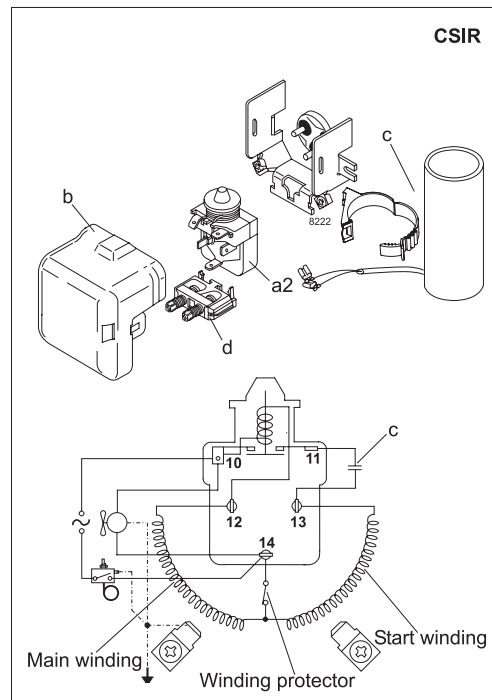

Accessories for	SC18CLX.2	Figure	Code number	Test conditions	EN 12900/ CECOMAF*	ASHRAE LBP*
PTC starting device	6.3 mm spade connectors	a1	—	Condensing temperature	45°C	45°C
	4.8 mm spade connectors		—	Ambient temperature	32°C	32°C
Starting relay	6.3 mm spade connectors	a2	117U6013	Suction gas temperature	32°C	32°C
Cover		b	103N2009	Liquid temperature	no subcooling	32°C
Start. capacitor 125 µF	6.3 mm spade connectors	c	117U5012			
Cord relief		d	103N1004			
Protection screen for PTC		g	—			
				Mounting accessories	Code number	
				Bolt joint for one comp.	Ø: 16 mm	118-1917
				Bolt joint in quantities	Ø: 16 mm	118-1918
				Snap-on in quantities	Ø: 16 mm	118-1919

Secop can accept no responsibility for possible errors in catalogues, brochures and other printed material. Secop reserves the right to alter its products without notice. This also applies to products already on order provided that such alterations can be made without subsequential changes being necessary in specifications already agreed. All trademarks in this material are property of the respective companies. Secop and the Secop logotype are trademarks of Secop GmbH. All rights reserved. www.secop.com