



# Tecumseh

## Compresor

Código de tensión : FZ

# AE4450Y-FZ1C

Frío Comercial Positivo (HP)

220 - 240V 1~ 50 Hz

## R134a / R513A

## AE4450Y-FZ1C

Condiciones	Frecuencia	Potencia frigorífica nominal		Potencia sonora ISO3745 / ISO 3743-1
		Watts	BTU/h	
EN12900_MHP / R134a	50 Hz	672	2292	56 dBA
EN12900_MHP / R513A	50 Hz	715	2439	56 dBA

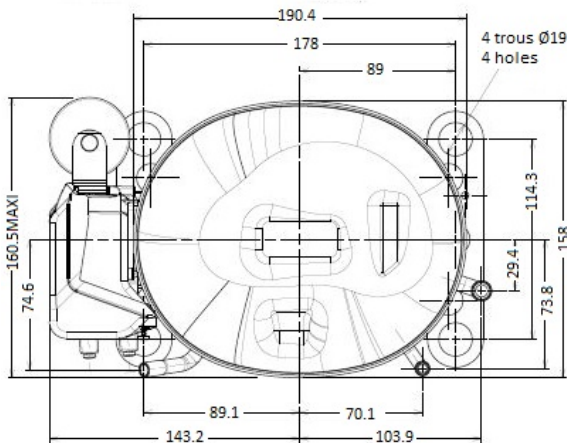
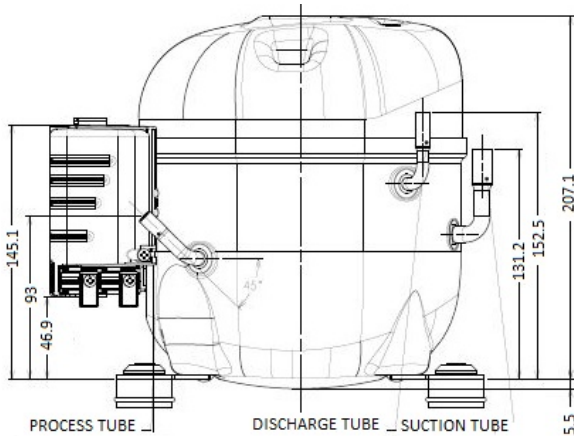

\* EN12900\_MHP : T°Cond. 45.0°C / T°Evap. -10.0°C / T°Gases Aspirados. 20.0°C  
T°Subenfriamiento. 0.0K

Homologaciones :



<b>Cilindrada (cc)</b>	13,24
<b>Peso neto (kg)</b>	11.7
<b>Cantidad de aceite (cc)</b>	380.0
<b>Tipo de aceite</b>	P.O.E
<b>Expansión</b>	Capilar/regulador de presión
<b>Enfriamiento</b>	Ventilado
<b>Fase principal (Ohm)</b>	4.8
<b>Fase auxiliar (Ohm)</b>	18.2
<b>Intensidad</b>	
Nominal (A)	3.2
De arranque (A)	17
<b>Tipo de componentes eléctricos</b>	CSIR
<b>Protector</b>	T0616
Temporización	2.8s - 5.2s / 18 A
Temperatura de apertura	130° C
Temperatura de cierre	61° C
<b>Condensador de arranque</b>	88 µF / 250 V
<b>Relé de intensidad</b>	MTRP0012
Activación	8,5A
Desactivación	7,15A
<b>Diámetro exterior del tubo</b>	
Ø del tubo de aspiración	9.5 (3/8")
Ø del tubo de descarga	6.35 (1/4")
Ø del tubo de carga	6.35 (1/4")

Tecumseh se reserva el derecho de modificar la información contenida en este documento sin preaviso



**Tecumseh**

<b>AE4450Y-FZ1C</b>	<b>Tension FZ : 220 - 240V 1~ 50 Hz</b>
---------------------	---

Les performances sont données dans les **conditions EN12900\_MHP** :  
 Condition Dew  
 The performance data are in **EN12900\_MHP conditions** :  
 Dew Condition

Gaz aspirés : 20.0 °C  
 Sous refroidissement : 0.0 K  
 Return gas : 20.0 °C  
 Subcooling : 0.0 K

© 2021 Tecumseh Products Company  
All rights reserved

**50 Hz R134a**

**N°3079**

4   T condensation	5   T évaporation	(°C)	-25	-20	-15	-10	-5	0	5	10	15
<b>30</b>	1   P frigorifique	(Watt)	386	510	656	828	1032	1269	1546	1864	2229
	2   P absorbée	(W)	241	271	299	326	353	381	412	447	487
	3   I absorbée	(A)	2.19	2.26	2.33	2.41	2.49	2.59	2.68	2.79	2.90
<b>40</b>	1   P frigorifique	(Watt)	322	437	569	725	907	1119	1365	1650	1976
	2   P absorbée	(W)	244	285	322	356	390	424	459	497	538
	3   I absorbée	(A)	2.16	2.26	2.37	2.49	2.61	2.74	2.88	3.02	3.17
<b>50</b>	1   P frigorifique	(Watt)		364	482	619	779	964	1180	1429	1716
	2   P absorbée	(W)		288	337	382	426	468	510	554	600
	3   I absorbée	(A)		2.26	2.41	2.57	2.73	2.90	3.07	3.25	3.44
<b>60</b>	1   P frigorifique	(Watt)			398	516	652	810	993	1206	1453
	2   P absorbée	(W)			341	401	457	510	563	616	670
	3   I absorbée	(A)			2.45	2.65	2.85	3.05	3.27	3.48	3.71

**50 Hz R513A**

**N°3177**

4   T condensation	5   T évaporation	(°C)	-25	-20	-15	-10	-5	0	5	10	15
<b>30</b>	1   P frigorifique	(Watt)	445	576	727	900	1099	1327	1587	1882	2215
	2   P absorbée	(W)	268	297	324	349	376	407	444	490	548
	3   I absorbée	(A)	2.43	2.47	2.52	2.58	2.66	2.76	2.89	3.06	3.27
<b>40</b>	1   P frigorifique	(Watt)	363	483	621	779	960	1167	1403	1672	1976
	2   P absorbée	(W)	266	309	346	380	413	447	485	530	584
	3   I absorbée	(A)	2.36	2.46	2.55	2.65	2.76	2.89	3.04	3.22	3.44
<b>50</b>	1   P frigorifique	(Watt)		395	514	652	810	992	1200	1438	1709
	2   P absorbée	(W)		306	359	405	448	491	534	582	637
	3   I absorbée	(A)		2.42	2.57	2.72	2.88	3.04	3.22	3.42	3.65
<b>60</b>	1   P frigorifique	(Watt)			419	531	661	813	989	1191	1425
	2   P absorbée	(W)			357	421	479	534	588	643	703
	3   I absorbée	(A)			2.57	2.78	2.99	3.19	3.41	3.64	3.90

1 = cooling capacity 2 = power input 3 = current 4 = condensing temperature 5 = evaporating temperature

**Nota : Tecumseh se réserve le droit de modifier les informations contenues dans ce document sans préavis.**

**Note : Tecumseh reserves the right to change information contained in this document without notification.**